



[www.ikh.fi](http://www.ikh.fi)

# JACKS, PRESSES





[www.ikh.fi](http://www.ikh.fi)

## 11. JACKS, PRESSES

Arm sets .....	7
Air hydraulic bottle jacks .....	3
Air hydraulic garage jacks .....	4
Body knocker set .....	12
Body repair kits .....	6,12
Bottle jacks .....	2,13
Bumping tool .....	12
Cranes .....	9
Creepers .....	14
Drum lifting clamp .....	12
Hammer set .....	12
High lift transmission jacks .....	10
Hydraulic cylinders .....	7,8
Hydraulic drum dolly .....	12

Hydraulic pipe bender .....	5
Hydraulic pumps .....	6,7
Jacking beam .....	10
Mechanic's bed .....	14
Oil filter crusher .....	11
Pulling cylinder .....	8
Scissor jacks .....	13
Stands .....	13
Toe jack .....	2
Transmission jack .....	9
Trolley jacks .....	3,13
Wheel dolly .....	11
Workshop presses .....	5



# BOTTLE JACKS



## For professionals! For working!

The continuous product development of MEGA is done together with professional users. From the basis of this co-operation the MEGA product's reliability, durability and practicality is built.

**MEGA is made for working!**



• can also be used horizontally

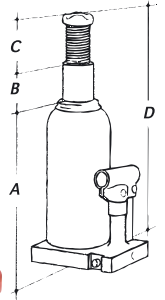

2 tn MG02	5 tn MG05	10 tn MG10	15 tn MG15	20 tn MG20	30 tn MG30	50 tn MG50	100 tn MGD100
<ul style="list-style-type: none"> <li>• capacity 2000 kg</li> <li>• dimensions: A 160 B 100 C 50 D 310</li> <li>• oil sump 70 cm<sup>3</sup></li> <li>• safety valve</li> <li>• weight 3,5 kg</li> <li>• packing size : 1</li> </ul> EAN 6418914615397	<ul style="list-style-type: none"> <li>• capacity 5000 kg</li> <li>• dimensions: A 212 B 150 C 75 D 437</li> <li>• oil sump 160 cm<sup>3</sup></li> <li>• safety valve</li> <li>• weight 4,9 kg</li> <li>• packing size : 1</li> </ul> EAN 6418914615403	<ul style="list-style-type: none"> <li>• capacity 10.000 kg</li> <li>• dimensions: A 219 B 150 C 75 D 444</li> <li>• oil sump 275 cm<sup>3</sup></li> <li>• safety valve</li> <li>• weight 6,5 kg</li> <li>• packing size : 1</li> </ul> EAN 6418914615410	<ul style="list-style-type: none"> <li>• capacity 15.000 kg</li> <li>• dimensions: A 228 B 150 C 75 D 453</li> <li>• oil sump 410 cm<sup>3</sup></li> <li>• safety valve</li> <li>• weight 8,75 kg</li> <li>• packing size : 1</li> </ul> EAN 6418914615427	<ul style="list-style-type: none"> <li>• capacity 20.000 kg</li> <li>• dimensions: A 234 B 150 C 75 D 459</li> <li>• oil sump 525 cm<sup>3</sup></li> <li>• safety valve</li> <li>• weight: 11 kg</li> <li>• packing size : 1</li> </ul> EAN 6418914615434	<ul style="list-style-type: none"> <li>• capacity 30.000 kg</li> <li>• dimensions: A 242 B 150 C 75 D 467</li> <li>• oil sump 800 cm<sup>3</sup></li> <li>• safety valve</li> <li>• weight 14,8 kg</li> <li>• packing size : 1</li> </ul> EAN 6418914615441	<ul style="list-style-type: none"> <li>• capacity 50.000 kg</li> <li>• dimensions: A 252 B 150 C 75 D 402</li> <li>• oil sump 1350 cm<sup>3</sup></li> <li>• safety valve</li> <li>• weight 28,8 kg</li> <li>• packing size : 1</li> </ul> EAN 6418914615458	<ul style="list-style-type: none"> <li>• capacity 100.000 kg</li> <li>• dimensions: A 300 B 150 C 75 D 450</li> <li>• two pumps, the other for quick pumping of cylinder to the working height, the other for actual lifting</li> <li>• pressure gauge</li> <li>• weight 87 kg</li> <li>• packing size: 1</li> </ul> EAN 6418914637146
<ul style="list-style-type: none"> <li>• repair kit no. MGR02</li> </ul> EAN 6418914615326	<ul style="list-style-type: none"> <li>• repair kit no. MGR05</li> </ul> EAN 6418914615243	<ul style="list-style-type: none"> <li>• repair kit no. MGR10</li> </ul> EAN 6418914615250	<ul style="list-style-type: none"> <li>• repair kit no. MGR15</li> </ul> EAN 6418914615267	<ul style="list-style-type: none"> <li>• repair kit no. MGR20</li> </ul> EAN 6418914615274	<ul style="list-style-type: none"> <li>• repair kit no. MGR30</li> </ul> EAN 6418914615281	<ul style="list-style-type: none"> <li>• repair kit no. MGR50</li> </ul> EAN 6418914615298	

## BOTTLE JACKS, low type



5 tn MGS05	10 tn MGS10	20 tn MGS20
<ul style="list-style-type: none"> <li>• capacity 5000 kg</li> <li>• dimensions: A 135 B 70 C 40 D 245</li> <li>• weight 3,8 kg</li> <li>• packing size: 1</li> </ul> EAN 6418914615304	<ul style="list-style-type: none"> <li>• capacity 10.000 kg</li> <li>• dimensions: A 131 B 62 C 30 D 223</li> <li>• weight 5,5 kg</li> <li>• packing size: 1</li> </ul> EAN 6418914615311	<ul style="list-style-type: none"> <li>• capacity 20.000 kg</li> <li>• dimensions: A 190 B 105 C 55 D 350</li> <li>• weight 10 kg</li> <li>• packing size: 1</li> </ul> EAN 6418914615328
<ul style="list-style-type: none"> <li>• repair kit no. MGRS05</li> </ul> EAN 6418914615144	<ul style="list-style-type: none"> <li>• repair kit no. MGRS10</li> </ul> EAN 6418914615151	<ul style="list-style-type: none"> <li>• repair kit no. MGRS20</li> </ul> EAN 6418914615168

## BOTTLE JACKS, telescopic



12 tn MGT12	5 tn MGT05
<ul style="list-style-type: none"> <li>• capacity 12000 kg</li> <li>• dimensions: A 245 B 326 C 571</li> <li>• weight 16 kg</li> <li>• packing size: 1</li> </ul> EAN 6418914615380	<ul style="list-style-type: none"> <li>• capacity 5000 kg</li> <li>• dimensions: A 215 B 300 C 515</li> <li>• weight 7,5 kg</li> <li>• packing size: 1</li> </ul> EAN 6418914615373
<ul style="list-style-type: none"> <li>• repair kit no. MGRT12</li> </ul> EAN 6418914615229	<ul style="list-style-type: none"> <li>• repair kit no. MGRT05</li> </ul> EAN 6418914615212



## TOE JACK MGMGL10

- ideal for lifting low vehicles for example forklifts and difficult lifting, supporting and positioning in jobs where space is tight
  - heavy-duty structure
  - extra low profile lifting toe 25 mm
  - the toe is adjustable to 2 fixed positions
  - includes bottle jack 10 tns MG10
  - packing size: 1
- EAN 6418914522206

## AIR HYDRAULIC BOTTLE JACKS



- these jacks use the compressor of the truck
- fitted with a manual pump, they can be operated as a portable bottle jack
- equipped with safety valve
- these jacks are designed to withstand 50% over their loaded capacity
- extension screw gives added height when necessary
- fitted with carrying handle
- air pressure 7–10 bar
- air flow 270 l/min
- ideal for truck and trailer roadside service as well as in repair shops

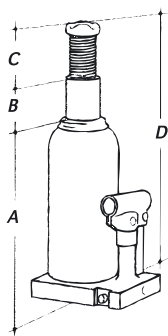

### 20 tn MGH20

- capacity 20 000 kg
- dimensions (mm): A 234, B 150, C 75, D 459
- weight 15,5 kg
- repair kit no. MGRH20
- packing size: 1
- EAN 6418914614864

### 30 tn

#### MGH30A

- capacity 30 000 kg
- dimensions: (mm) A 255, B 138, C 75, D 468
- no hand pump in jack
- using comfort and safety: both lifting up and letting down happens with mechanic valves in jack's hoses
- metallic storing box
- weight 25,5 kg
- packing size: 1
- EAN 6418914637276



## TROLLEY JACKS



- safety overload valve
- hydraulic stroke limitation
- LCS lowering control system
- safety lock to avoid involuntary actions
- foot pedal for quick approach of the lifting saddle to load
- polyamide wheels will not damage garage floors, do not rust and are quiet in operation
- ergonomic handle with rubber grip

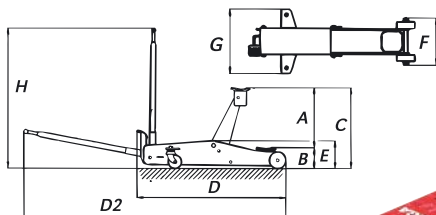

### 1,5 tn high

#### MGT015H

- capacity 1500 kg
- lifting height 775 mm
- the inside wheel allows for excellent manoeuvrability
- weight 60,5 kg
- dimension (mm): A 665, B 110, C 775, D 1250, D2 2180, E 165, F 360, G 360
- packing size 1
- EAN 6418914615335

### 2 tn, very low model

#### MGT2

- capacity 2000 kg
- lifting height 465 mm
- due to reduced height allows easier access
- weight 32 kg
- dimensions (mm): A 390, B 75, C 465, D 880, D2 1810, E 135, F 260, G 360
- packing size: 1
- EAN 6418914511903

### 3 tn

#### MGT3

- capacity 3000 kg
- lifting height 525 mm
- weight 50 kg
- dimensions (mm): A 385, B 140, C 525, D 1150, D2 2080, E 185, F 260, G 360
- packing size: 1
- EAN 6418914528963

### TROLLEY JACK 10 tn

#### MGTJ10

- capacity 10 000 kg
- lifting height 575 mm
- safety overload valve
- weight 111,5 kg
- dimensions (mm): A 380, B 195, C 575, D 1600, D2 2600, E 260, F 345, G 425, H 1100
- repair kit MGRTJ10
- packing size: 1
- EAN 6418914615366



# AIR HYDRAULIC GARAGE JACKS



- min. pressure required 7 bar
- necessary air flow 270 l/min
- chromium-molybdenum-vanadium composition, anti-rust and anti-seizing treatment



- hand lever locks in four different positions: 45°, horizontal, vertical or collapsed for easier transport
- fitted with a butt to prevent hands rubbing on the ground
- safety overload valve
- LCS-lowering control system
- single control switch – handy and easy to use

- comply with the requirements of the prEN1494 standard
- hydraulic stroke limitation
- efficient and safe lifting operation, smooth and regular load descent
- packing size: 1

F = lifting height with additional piece  
G = width without wheels  
H = overall width

Order no.	MGN103	MGN152	MGN154	MGN203	MGN30	MGN30H korkea
Capacity	10-20-35 t	15-30 t	15-30-50-80 t	20-35-65 t	30 t	30 t
Dimens. mm:						
A	1280	1280	1280	1280	1280	1280
B	805	805	1065	1055	805	895
C	125	185	155	180	215	360
D	160	185	235	235	115	250
E	285	370	390	415	330	610
F	345	470	490	515	430	710
G	183	183	210	210	183	183
H	280	300	327	327	300	300
Weight kg	42,5	51,5	75,5	74,5	59	82
EAN	6418914649460	6418914649477	6418914649491	6418914649484	6418914649507	6418914649514
Repair kit no.	MGRN10-3	MGRN15-2	MGRN15-4	MGRN20-3	MGRN30	MGRN30

# WORKSHOP PRESSES



## 15 tn

### MGK15A

• dimen.:

- A 610 G1 150
- B 420 G2 300
- C 950 R1 150
- D 90 R2 75
- E 500 R 225

- weight 69 kg
- pressure gauge
- workbench adjustable height
- automatic spring return piston
- packing size: 1
- EAN 6418914614888

- repair kit no MGRKS15A



## 15 tn

### MGKS15A

• dimen.:

- A 610 G1 150
- B 650 G2 600
- C 1675 R1 150
- D 90 R2 75
- E 500 R 225

- weight 80 kg
- pressure gauge
- workbench adjustable height
- automatic spring return piston
- packing size: 1
- EAN 6418914614895

- repair kit no MGRK15A

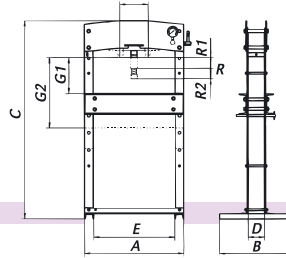

## 30 tn

### MGK30A

• dimen.:

- A 670 G1 150
- B 650 G2 600
- C 1750 R1 150
- D 110 R2 75
- E 550 R 225

- weight 128 kg
- pressure gauge
- workbench adjustable height
- automatic spring return piston
- packing size: 1
- EAN 6418914614901

- repair kit no MGRK30A

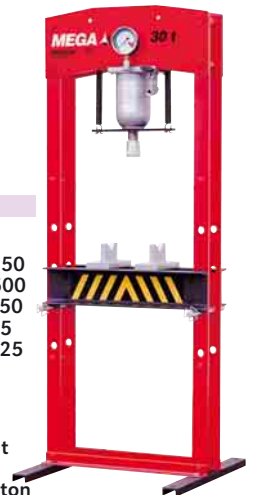

## 50 tn

### MGKPD50A

• dimen.:

- A 880 G1 165
- B 650 G2 615
- C 1810 R1 120
- D 145 R2 75
- E 710 R 170
- M 250

- weight 220 kg
- pressure gauge
- workbench adjustable height
- winch to assist easy and rapid handling
- automatic spring return piston
- 2 manually operated pumps – 2 speeds
- built-in pressure relief valve
- packing size: 1
- EAN 6418914614871

- repair kit no MGRKPD50A

## 50 tn

### MGKPD50AN

• dimen.:

- A 880 G1 165
- B 650 G2 615
- C 1810 R1 120
- D 145 R2 75
- E 710 R 195
- M 250

- weight 239 kg
- air pressure and manually operated pump
- recommended air pressure 7 bar
- air consumption 270 l/min
- pressure gauge
- winch to assist easy and rapid handling
- automatic spring return piston
- 2 pumps > 2 speeds
- built-in pressure relief valve
- packing size: 1
- EAN 6418914628113

- repair kit no MGRBKN-09



## 50 tn with pedal

### MGKPD50ANF

- packing size: 1
- EAN 6418914699328



## PUNCH SET FOR WORKSHOP PRESSES

- includes adapter, punch set and plate



Order no.	Suitable for
MGA5552-15	15 tn workshop presses
MGA5552-30	30 ja 50 tn workshop presses

## HYDRAULIC PIPE BENDER

### MGCVT03

- capacity 20 tn
- for GAS, DIN 2440 and DIN 2441 -type pipes
- max. bending angle 180°
- bending shoes: 1/2", 3/4", 1", 1 1/4", 1 1/2", 2", 2 1/2", 3"
- tripod stand
- safety valve
- weight 128 kg
- piston retracts automatically when release valve is opened
- packing size: 1
- EAN 6418914614789

- repair kit no MGRCVT03
- manual pump 1250 cm<sup>3</sup> MGC-BM1

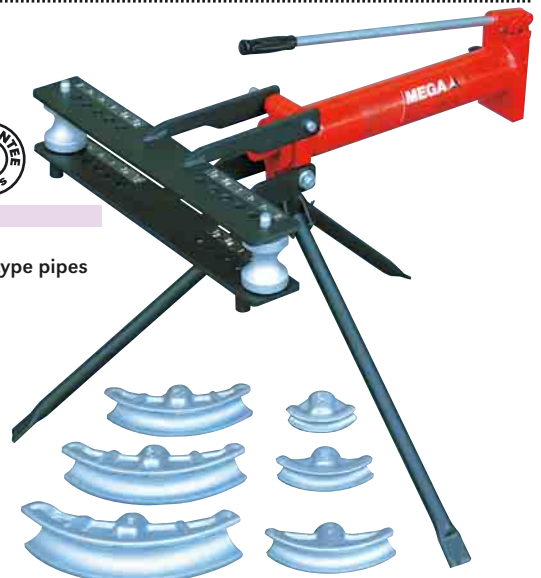

# BODY REPAIR KITS



- the pump is fitted with an overpressure valve
- piston stroke limited with mechanical stop, retracts by spring
- the threading connection of components provides higher strength and safety
- supplied in a metal box
- **IMPORTANT:** as cylinders are bigger in capacity than components, namely chains, cylinder toes, tube extensions etc., they should never exceed half their rated capacity

### 5 tn MGC05S

- NOTE! Max. working load 1 tn
- weight 28 kg
- packing size: 1
- EAN 6418914614796

• repair kit no. MGRC05S

### 10 tn MGC10S

- NOTE! Max. working load 2 tn
- weight 48 kg
- packing size: 1
- EAN 6418914614802

• repair kit no. MGRC10S



## SPARE PARTS FOR BODY REPAIR KITS

Order no.		Suitable for	EAN
MGCT25	pulling cylinder 2,5 tn (stroke 127 mm, weight 2,25 kg)	MGC05S	6418914701656
MGCT05	pulling cylinder 5 tn (stroke 138 mm, weight 3,9 kg, repair kit MGRCT-5)	MGC10S	6418914614765
MGCT10	pulling cylinder 10 tn (stroke 138 mm, weight 8,3 kg)	MGC10S	6418914614772
MGCT10B	pushing cylinder 10 tn	MGC10S	6418914630574
MGC-BM04	manual pump 400 cm <sup>3</sup>	MGC05S, MGC10S	6418914630536
MGC-A5541	hose 1,5 m	MGC05S, MGC10S	6418914630611
MGSH1	spreader 1 tn	MGC05S, MGC10S	6418914630581
MGA5086	chain	MGC10S	6418914630628



## HYDRAULIC PUMP

### MGNS1

- single-acting, one-speed
- with pedal
- air driven pump for operation where electric power is not available or dangerous
- safety relief valve
- recommended air pressure 7–10 kg/cm<sup>2</sup>, minimum air flow 270 l/min.
- working pressure 700 kg/cm<sup>2</sup>
- oil volume 500 cm<sup>3</sup>
- oil flow 50 cm<sup>3</sup>/min
- dim.: A 440 mm  
B 120 mm  
C 150 mm
- weight 7 kg
- packing size: 1
- EAN 6418914077133

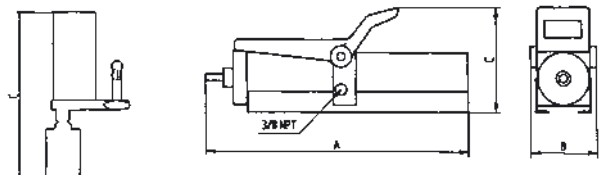

**IMPORTANT:** It is recommended to use an air filter-regulator-lubricator unit with pump to resist corrosion and for longer life.



### HYDRAULIC PUMP Double-acting

#### MGBMD3

- double-acting and two-speed
- can operate both in horizontal or vertical position
- with safety relief valve
- working pressure 700 kg/cm<sup>2</sup>
- effective oil volume 3000 cm<sup>3</sup>
- weight 17 kg
- dimensions (mm):  
A 730 H 12  
B 146 I M8x1,25  
C 185 J 80  
D 595 J' 607  
E 125 L 665  
F 110 M 80  
G3/4 -18NPT N 65
- packing size: 1
- EAN 6418914701717

Repair kit MGRBMD-3

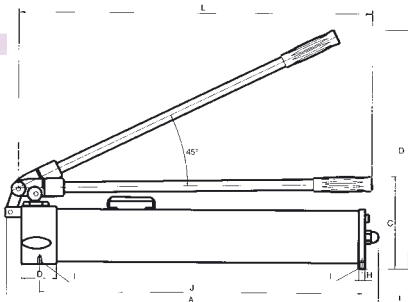
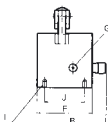

### HOSE 1,5 m with couplings MGA5555

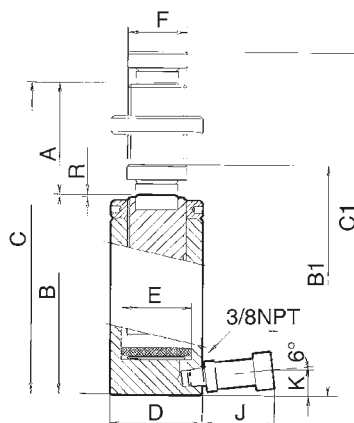

### HYDRAULIC CYLINDER 31 tn

#### MGCSF31D

- työpaine 700 kg/cm<sup>2</sup>
- männät korroosiosuojattu
- yksitoiminen, jousipalautteinen
- particularly recommended for foundations support in construction, bridge building and maintenance of heavy machinery in public works or steel industry
- stroke (A) 150 mm
- max. capacity 303,1 kN
- effective area 44,18 cm<sup>2</sup>
- oil volume 660 cm<sup>3</sup>
- weight 14,5 kg
- dim.: B 272 F TR 2 1/4 x5  
C 422 J 70  
D 100 K 23  
E 75 R 2

• packing size: 1  
EAN 6418914701670

Repair kit MGRTO4



### HOSE 1,5 m with couplings MGA5555

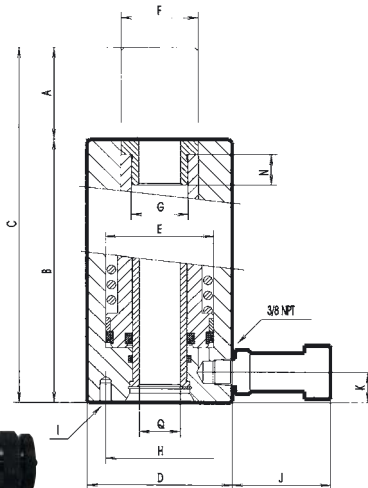

### HYDRAULIC CYLINDERS

- single-acting, spring-return
- hole model
- suitable for pushing and pulling, with mounting holes and threaded areas for easy coupling or special tooling applications
- suitable for installation work
- packing size: 1



Order no.	20 tn MGCSH20	30 tn MGCSH30
Capacity	196,6 kN	291,7 kN
Effective area	28,86 cm <sup>2</sup>	42,51 cm <sup>2</sup>
Oil volume	140 cm <sup>3</sup>	270 cm <sup>3</sup>
Dim. (mm)		
A (stroke)	48 mm	63 mm
B	172 mm	200 mm
C	220 mm	263 mm
D	92 mm	110 mm
E	70 mm	85,72 mm
F	50,5 mm	62 mm
G	M37x1,5 mm	M46x1,5 mm
H	82,6 mm	92,1 mm
I	3/8-16 UNC	3/8-16 UNC
J	70 mm	70 mm
K	20 mm	20 mm
N	20 mm	22 mm
Q	26,5 mm	33 mm
EAN	6418914701700	6418914710153

### HYDRAULIC CYLINDER 31 tn

#### MGCSB31B

- single-acting
- stroke (A) 50 mm
- max. capacity 303,1 kN
- effective area 44,18 cm<sup>2</sup>
- oil volume 220 cm<sup>3</sup>
- weight 6,9 kg
- ideal for a wide range of application in civil engineering, heavy fabrication, construction, maintenance and lifting of very heavy loads
- dim.: B 125 F 57,15  
C 175 J 70  
D 100 K 23  
E 75 R 2

• packing size: 1  
EAN 6418914701663

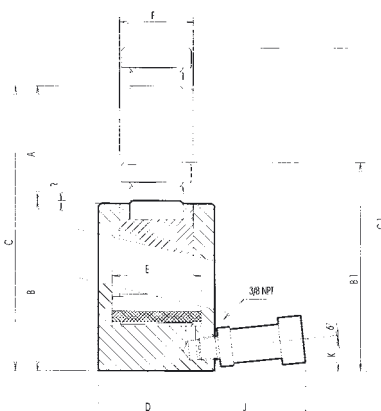



## HYDRAULIC WORKSHOP PRESS 12 tn

**XTOP012**

- capacity 12 tn
  - operating area 0 - 918 mm
  - stroke 180 mm
  - width of the frame 510 mm
  - height 1650 mm
  - packing size: 1
- EAN 6418914538207



## ENGINE STAND

**XTOP014**

- max. capacity 450 kg
  - with wheels
  - packing size: 1
- EAN 6418914547063



## ENGINE CRANE 2 tn

**XTOP010**

- capacities: 500/1000/1500/2000 kg
  - max. lifting height 2200 mm / 500 kg
  - max. rod barrier length 1560 mm / 500 kg
  - framework height 1500 mm
  - max. length 1740 mm, width 990 mm
  - metallic wheels
  - folding for easy storing
  - packing size: 1
- EAN 6418914538184

## DOLLY

**XTOP019**

- max. carrying capacity 680 kg/dolly
  - 100 mm nylon wheels
  - dolly for moving car - two dollies enables car moving in garage etc.
  - packing size: 1
- EAN 6418914547117

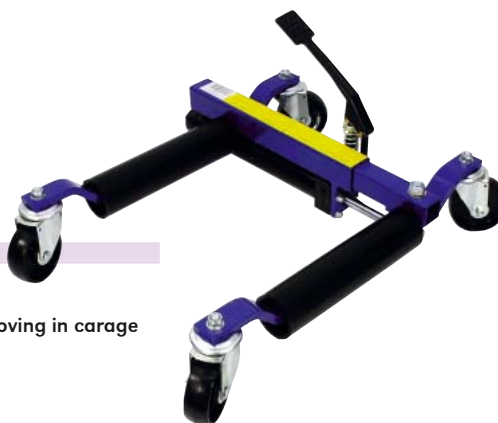



Lifting and landing of platform with foot pedal

## REPAIRING TABLE FOR MOTOR CYCLE

### XTOP011

- lifting and landing of platform with foot pedal
  - safety locking pin
  - front wheel clamp
  - end stopper
  - service opening (745 x 290 mm) for rear wheel removal
  - metallic wheels and adjustment/anti-slip pins
  - material thickness 3 mm
  - max. capacity 450 kg
  - height of plane min. 175 mm, max. 750 mm
  - plane W680, L2200 mm
  - driving bridge W680 mm, L620 mm
  - packing size: 1
- EAN 6418914538191



Service opening  
(745 x 290 mm)  
for rear wheel removal

Pivoted/tilting board support for easy positioning of board



## **GYPSUM BOARD/CHIPBOARD LIFT**

### **XTOP024**

- lifting height 86,5 cm - 335 cm
  - max. weight of the board 68 kg /  
max. board size 1,22 x 4,88 m
  - very easy folding for transport and storage
  - packing size: 1
- EAN 6418914548961

CRANES



- extendable arm
- equipped with wheel - easy to move
- rotating lift hook
- folding
- packing size: 1



Order no.	MGFC05A	MGFC10A
Capacity (kg)	500	1000
Dimensions (mm)		
A	1400	1675
A2	1400	1675
E	1970	2275
G	2080	2415
J	1500	1695
K	820	935
L	970	1085
M	80	80
R Min.	1050	1260
R Med.	1150	1405
R Max.	1250	1550
P	465	545
S	450	450
Weight (kg)	92	121
EAN	6418914621022	6418914621039
Repair parts	MGFC05A-73	MGFC10A-73



On pictures MGFC10A

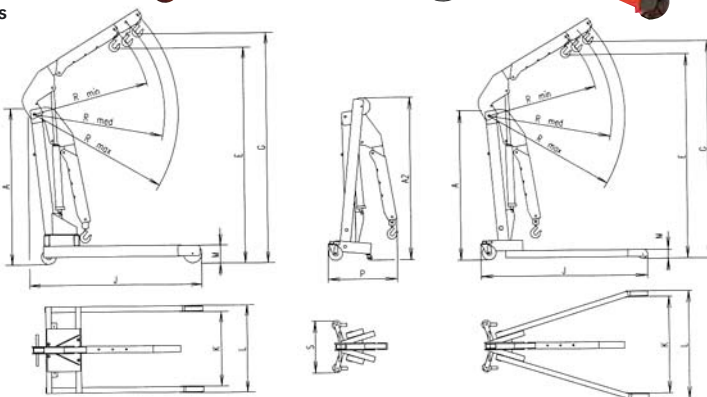

Order no.	Position		
	1	2	3
MGFC05A	500 kg	400 kg	325 kg
MGFC10A	1000 kg	800 kg	700 kg



**TRANSMISSION JACK  
1 tn**

**MGGCB2**

- the saddle is fitted with chains to ensure safe movement of load
- equipped with a detachable pump, which allows the jack to be used in any position

- capacity 1000 kg
- table dim.: 375 x 375 mm
- minimum height. 160 mm
- maximum height 730 mm
- hydraulic stroke 570 mm
- weight 86 kg

• packing size: 1  
EAN 6418914511927





**TRANSMISSION JACK  
500 kg**

**XTOP016**

- max. capacity 500 kg
- min. height 1125 mm, max. height 1940 mm
- four castor wheels
- weight 30 kg
- packing size: 1
- EAN 6418914547087

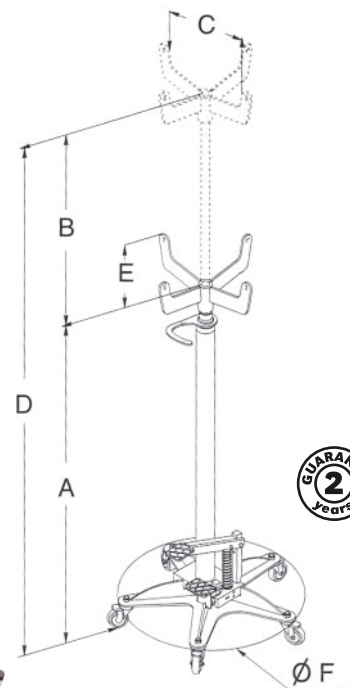

**HIGH LIFT  
TRANSMISSION JACKS**

- lifting and lowering of the load using the foot pedal – leave the hands free for job
- the large sized base provides high stability
- five swivel castors – easily manoeuvrable
- safety valve against overload
- packing size: 1

Order no.	300 kg MGF300	750 kg MGF750	1200 kg MGFMGT1200A
Capacity	300 kg	750 kg	1200 kg
Dimens.	A 1184 B 850 C 304 D 2034 E 89 F 550	A 1193 B 826 C 304 D 2013 E 89 F 650	A 900 B 1000 C 304 D 1900 E 89 F 650
Weight	24,5 kg	32,5 kg	36 kg
EAN	6418914614833	6418914614840	6418914511910
Repari kit		MGRF750	



**JACKING BEAM  
2000 kg**

**MGMA02**

- for use on four column lifting bridges or in pits
- enable the lifting of two wheels of the vehicle simultaneously
- they are thereby indispensable for jobs such as wheel alignment, brake and suspension repairs, etc. Suitable for any width of pit and rail
- the extendable arms and extension lifting saddles facilitate the exact positioning of all vehicles
- fitted with 2 extension adapters of 100 mm
- automatic mechanical locking device against unexpected descent
- capacity 2000 kg
- operating pressure 7-10 bar
- air flow 270 l/min
- weight 129 kg
- packing size: 1
- EAN 6418914621244

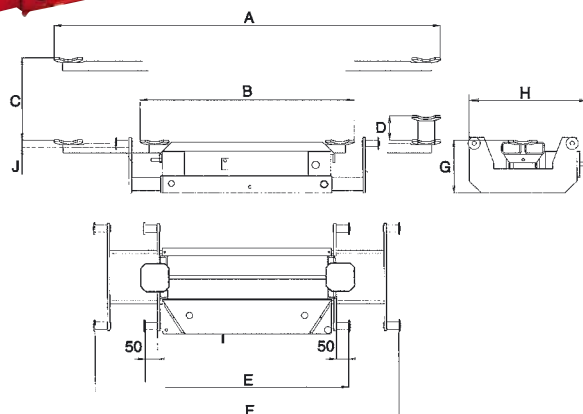
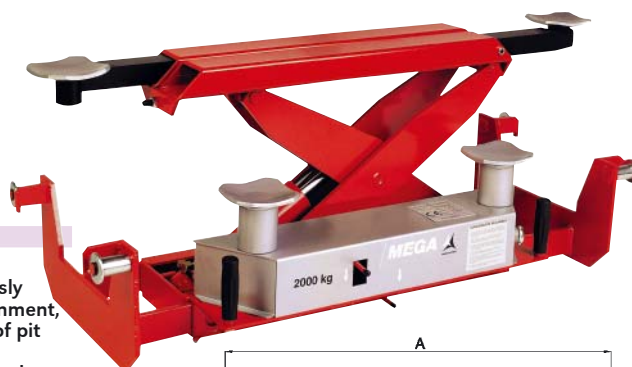

- dimensions: A 1575 mm
- B 870 mm
- C 340 mm
- D 100 mm
- E 830 mm
- F 1240 mm
- G 220 mm
- H 490 mm
- J 30 mm



## OIL FILTER CRUSHER

### MGAF12

- crushes used filter flat and collects residual oil, that can be carried away through a hose to drum
- crushed filters can be recycled as scrap metal
- saves space and minimizes disposal charges
- security switch is equipped to prevent pump from operating once the door is opened
- safety overload valve
- hydraulic stroke limitation
- operating pressure 7-10 bar
- air flow 270 l/min
- packing size: 1

EAN 6418914522213

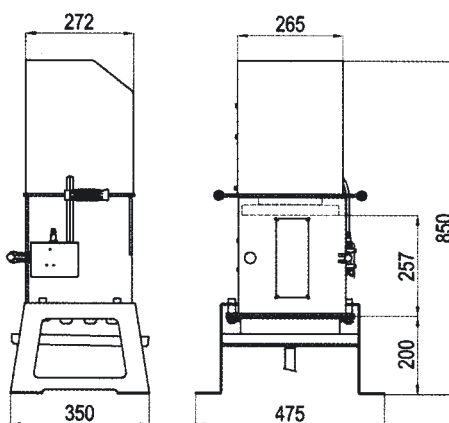

## WHEEL DOLLY

### MGR700

- specially designed for removal of twin and large size wheels
- lifting and lowering of the load using the foot pedals leave hands free for the job
- manual support lever to reduce the lifting strain when working at maximum capacity
- fitted with chain to ensure safe movement of the wheel
- hydraulic stroke limitation
- lowering control system
- safety overload valve
- capacity 700 kg
- max. lift 630 mm
- min. height to fork 105 mm
- adjustable five-position lifting arms 480 – 750 mm
- each arm includes two rollers with bearings
- the side fitting of the hydraulic unit leaves all the central space clear to access the wheel
- weight 134 kg
- packing size: 1

EAN 6418914522190

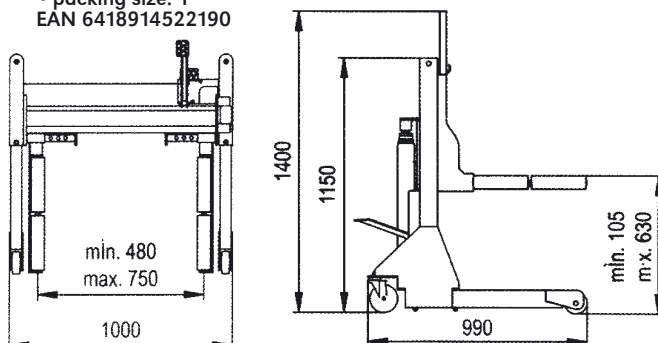

## HYDRAULIC DRUM DOLLY

### MGPB300

- for plastic and steel drums of 200 litres
  - max. load 300 kg
  - lifting and lowering of the load using the foot pedals
  - suitable for loading drums on most commercial vehicles
  - european pallets get inside the chassis
  - weight 70 kg
  - packing size: 1
- EAN 6418914648920



Automatic clamp: just position the clamp under the tight head of the drum. Both clamping and release are made automatically.



**MEGA**

**MEGA**

## DRUM LIFTING CLAMP

### MGAB300

- for 200 litre steel drums
  - max. load 300 kg
  - packing size: 1
- EAN 6418914648937



Can be used e.g. on cranes MGFC05A and MGFC10A.



## BODY-FRAME REPAIR KIT

- the cylinders operates both vertical and horizontal positions
- equipped with relief valve
- when using extension tubes the capacity must be reduced always 50 % per tube

**STRONG**  
*Line*



### 4 tn

#### XTPO1

- length of slave cylinder min. 267 mm
  - length of stroke of slave cylinder 120 mm
  - extension pipes: 80, 125, 215, 420, 490 mm
  - 7 different stoppers
  - wedge 0,5 tn
  - pump outletpressure 56,5 Mpa
  - oil capacity 350 g
  - weight 19 kg
  - plastic case
  - packing size: 1/30
- EAN 6418914706446



### 10 tn

#### XTPO2

- length of slave cylinder min. 322 mm
  - length of stroke of slave cylinder 130 mm
  - extension pipes: 110, 265, 365, 515 mm
  - 7 different stoppers
  - wedge 0,5 tn
  - pump outletpressure 63 Mpa
  - oil capacity 500 g
  - weight 31 kg
  - plastic case with wheels and handle
  - packing size: 1/15
- EAN 6418914706453



## Heavy duty BODY KNOCKER SET

### IKH7097

- content (1 of each):
  - hammer and shaft
  - small flat blade hook
  - large flat blade hook
  - round hook
  - small radius flat blade hook
  - screw
  - hook and chain
  - straight flat blade hook
  - round hook and adapter
  - reverse small flat blade hook
  - packing size: 1/2
- EAN 6418914709515



## HAMMER SET 9-pcs with changeable bits

### IKH50

- heads made of chrome-vanadium-steel, shaft made of die-forged steel
  - quick changeable bits 9 pcs, enables hammering of many different kind of shapes
  - packing size: 1/10
- EAN 6418914694699



## BUMPING TOOL 80 x 56 x 26 mm

### IKH7128

- packing size: 1
- EAN 6418914649347





**SCISSOR JACK 1 tn**

**TK1430A**

- zink coated
  - capacity 1000 kg
  - lift area 228–370 mm
  - packing size: 1/10/150
- EAN 6418914610576



**SCISSOR JACK 1 tn**

**TK1430B**

- closed
  - capacity 1000 kg
  - lift area 100–375 mm
  - packing size: 1/10
- EAN 6418914621565



**BOTTLE JACKS**



**8 tn**

**X009006B**

- capacity 8000 kg
  - TÜV-approved
  - packing size: 1/4
- EAN 6418914149939

**3 tn**

**X009006**

- capacity 3000 kg
  - TÜV-approved
  - packing size: 1/6
- EAN 6418914149915

**5 tn**

**X009006A**

- capacity 5000 kg
  - TÜV-approved
  - packing size: 1/4
- EAN 6418914149922

**12 tn**

**X009006C**

- capacity 12.000 kg
  - TÜV-approved
  - packing size: 1/4
- EAN 6418914149946

**20 tn**

**X009006D**

- capacity 20.000 kg
  - TÜV-approved
  - packing size: 1/2
- EAN 6418914149953



**AWD**

**TROLLEY JACK 2 tn**

**AWD009002**

- capacity 2000 kg
  - lift area 135–340 mm
  - TÜV-approved
  - packing size: 1/60
- EAN 6418914616080



**TROLLEY JACK 2,25 tn**

**TK1200**

- strong model
  - capacity 2250 kg
  - lift area 145–480 mm
  - weight 37 kg
  - TÜV-approved
  - packing size: 1/14
- EAN 6418914124240



**QUICK LIFT**  
(appr. with 6 lifts)

**QUICK LIFT**  
(appr. with 4 lifts)

**STRONG**  
*Line*

**TROLLEY JACK 1,5 tn**

- strong, low model
- light and durable, easy to carry
- capacity 1500 kg
- packing size: 1

Order no.	XTOP07	XTOP08
Material	aluminium/steel	aluminium
Min. saddle height	85 mm	90 mm
Max. saddle height	455 mm	445 mm
Hydraulic lift	370 mm	355 mm
Overall length	625 mm	609 mm
Overall width	310 mm	305 mm
Overall height	155 mm	159 mm
Weight	26,5 kg	18 kg
Packing size	1/200	1/100
EAN	6418914640214	6418914640221



**CAR STAND 2 tn**

**YT7015**

- 3 legs
- max. 2000 kg
- height 255–415 mm
- packing size: /10
- EAN 6418914621435



**STAND PAIRS**

**2 tn**

**XKP20**

- height 280–355 mm
- foldable feet
- packing size: 1
- EAN 6418914187047

**3 tn**

**XKP30**

- height 300–430 mm
- foldable feet
- packing size: 1
- EAN 6418914187054

**6 tn**

**XKP60**

- height 382–600 mm
- packing size: 1
- EAN 6418914187450



**MACHINERY STAND  
16 tn**

**T0651**

- min. height 580 mm
- max. height 1000 mm
- max. load 16 tn
- weight 32 kg
- is delivered individual (not pair)
- packing size: 1/13
- EAN 6418914511552



**FOLDING CREEPER**

**XTOP04A**

- cushioned bed and seat in one
- size as bed: L620 mm, W470 mm, H110 mm
- height of seat 470 mm
- wheels Ø 60 mm, 7 pcs
- packing size: 1
- EAN 6418914529960



**CREEPER**

**RAVE151**

- metal
- width 120 mm, total length 890 mm
- four turnable nylon wheels 50 mm
- weight 6 kg
- packing size: 1
- EAN 5701747061686

## PUSHER JACK

**IKH7513**

- double-gear system
  - max. pushing force 1000 kg
  - fastening holes
  - detachable under corner for fastening to wall
  - for adjustment of parquet/laminate floor, readjustment of low walls and for other lifting and adjustment work
  - packing size: 1/5
- EAN 6418914547162

